

ITEM	QTY	DESCRIPTION
1	2	TOP CAP SCREWS
2	1	HOLDER
3	1	O-RING
4	1	SPRING (JET NEEDLE)
5	1	WASHER <b>THICK</b> (JET NEEDLE)
6	1	E-RING
7	1	WASHER <b>THIN</b> (JET NEEDLE)
8	1	DIAPHRAGM
9	1	RING
10	1	SPRING
11	1	DIAPHRAGM
12	1	O-RING
13	1	O-RING, FUEL SCREW
14	1	WASHER
15	1	SPRING
16	1	FUEL SCREW
17	1	O-RING (NOZZLE)
18	1	SCREW
19	1	NEEDLE VALVE
20	1	SCREW
21	1	O-RING (FLOAT BOWL)
22	1	SCREW (DRAIN)
23	1	WASHER
24	1	SCREW
25	3	SCREW

## MK-BSR42-04

**Bombardier/ Can Am Application:**  
2000-2007 Can Am DS 650 ATV

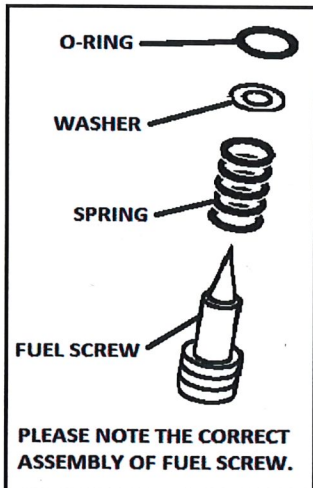
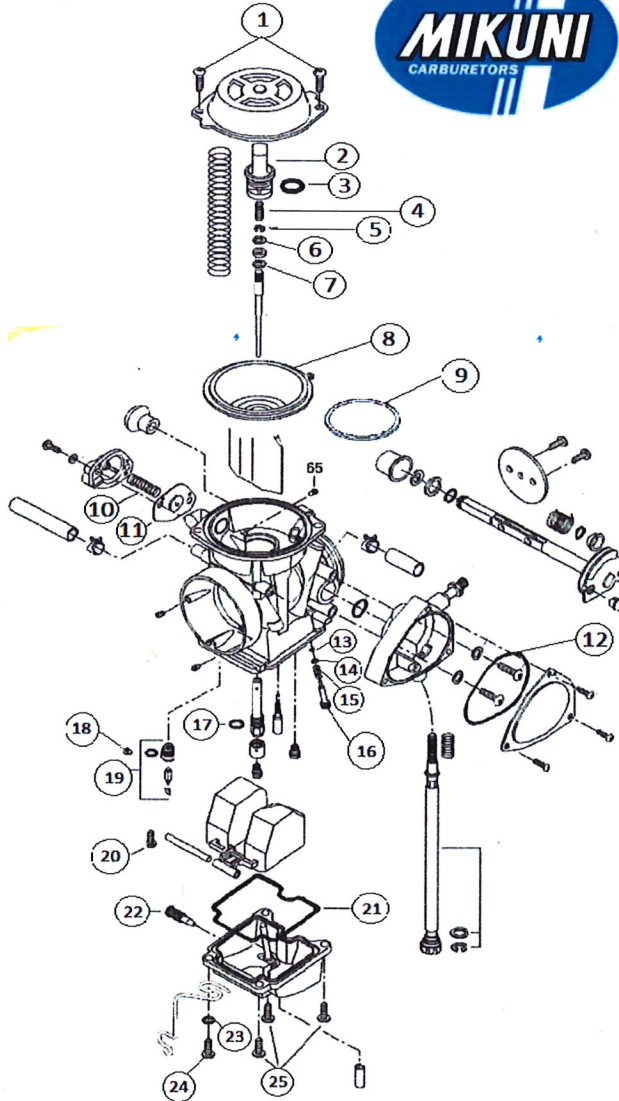

### \*\*REPLACEMENT JET NOTE

Due to varying model requirements, this kit does not include main or pilot jets

If needed, refer to the

following Mikuni Part numbers when acquiring these jets:

Main Jet: N10221-XXXX

Pilot Jet: N224103-XXXX

**MIKUNI AMERICAN CORPORATION**

[www.mikunipower.com](http://www.mikunipower.com)

HEAD OFFICE: 8910 MIKUNI AVENUE  
NORTHRIDGE, CALIFORNIA 91324-3496  
PHONES: (818) 885-1242  
FAX: (818) 993-7387/8